

2FC-S FILTER CARTRIDGE

Cartridge Part Number: EV9691-76



APPLICATIONS

- ◆ Steam and combi ovens
- ◆ Coffee brewers

FEATURES • BENEFITS

- ◆ Increased capacity for chlorine reduction and robust equipment protection
- ◆ Proprietary Fibredyne™ II media effectively inhibits the growth of bacteria on the filter media that can decrease product life
- ◆ Exclusive Fibredyne™ II media provides chlorine taste & odor reduction and micro-filters sediment down to 0.2* micron in size by mechanical means
- ◆ Helps protect drink system seals, pump, tubing and small orifices from clogging, corrosion and abrasive wear
- ◆ Compatible with Insurice®, QC7I Single, QL1, and QL3B heads
- ◆ Easy, sanitary, quick-change filter replacement
- ◆ NSF/ANSI Standard 53 certified to reduce cysts such as *Cryptosporidium* and *Giardia* by mechanical means
- ◆ NSF /ANSI Standard 42 certified for Bacteriostatic Effects and the reduction of Chlorine Taste & Odor, and Particulate Class I
- ◆ NSF/ANSI Standard 401 certified for Microplastics Reduction

INSTALLATION TIPS

- ◆ Install vertically and allow 2 1/2" (6.35 cm) clearance below the cartridge for easy removal and replacement.
- ◆ Flush cartridge by running water through the filter for five (5) minutes.
- ◆ Change cartridges when capacity is reached or when pressure falls below 10 psi (0.7 bar).
- ◆ It is recommended to replace cartridge at least once a year.

* Validated by ISO 17025 accredited lab for 99.999% reduction of *Pseudomonas diminuta* following the ASTM F838-05 protocol for the validation of 0.2 µm sterilizing grade filters.

EPA Est. No. 002623-IL-002

2FC-S REPLACEMENT CARTRIDGE

EV9691-76

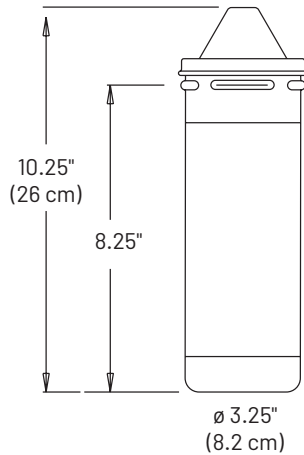

Specifications

Overall Dimensions

10.25" H x 3.25" D (26.0 cm x 8.2 cm)

Service Flow Rate

Maximum 1.5 gpm (5.67 Lpm)

Rated Capacity

6,000 gallons (22,712 L)

Operating Pressure

10 - 125 psi (0.7 - 8.6 bar), non-shock

Water Temperature

35 - 100°F (2 - 38°C)

Electrical Connection

None required

For Pentair Everpure Product Warranties visit:
<http://pentair.com/assets/foodservice-warranty>

The contaminants or other substances removed or reduced by this drinking water system are not necessarily in your water. Do not use with water that is microbiologically unsafe or of unknown quality without adequate disinfection before or after the system.

Since the conditions under which our products may be used are beyond our control, we cannot accept any liability with respect to the improper installation, application and/or use of our products.

System Tested and Certified by NSF International against NSF/ANSI Standards 42, 53, and 401 for the reduction of:

STANDARD NO. 42 –
AESTHETIC EFFECTS

Bacteriostatic Effects

Chemical Reduction

Taste & Odor

Chlorine

Mechanical Filtration

Nominal Particulate Class I

STANDARD NO. 53 –
HEALTH EFFECTS

Mechanical Filtration

Cyst

Turbidity

STANDARD NO. 401 –
EMERGING COMPOUNDS
/ INCIDENTAL

CONTAMINANTS

Mechanical Filtration

Microplastics



1040 Muirfield Drive | Hanover Park, IL 60133 | 800.942.1153 (US Only) 630.307.3000 Main | cseverpure@pentair.com | foodservice.pentair.com

All indicated Pentair trademarks and logos are property of Pentair. Third party registered and unregistered trademarks and logos are the property of their respective owners.

©2023 Pentair. All rights reserved.

EV9691-76 JL23